

Barmac VSI Crushers Barmac B-Series VSI



B6150SE

B7150SE

B9100SE



Barmac VSI – the proven producer

The Barmac B-Series Vertical Shaft Impact (VSI) crusher has had a huge impact on the global quarrying and minerals processing industries.

The Barmac B-Series VSI is unique due to its crushing process. Whereas most other types of crusher use metallic parts to crush rock, the Barmac VSI uses the rock fed into the machine to crush itself. This autogenous crushing process produces the best-shaped aggregate on the market today.

The high velocity impact crushing achieved in a Barmac B-Series VSI improves the soundness and shape of stone, reducing product moisture and easing the screening task while producing superior products at a minimum cost.

Unmatched performance

With thousands of units operating in aggregate and mineral processing installations around the world Barmac

B-Series VSIs, with their rock-on-rock crushing action, have an established track record of cost savings, durability and unmatched performance in the variety of tasks to which they have been applied. These include the production of quality aggregates, sand, material for heap leaching, pre-grinding and finished industrial minerals products.

Lowest total cost

Many benefits of the Barmac B-Series VSI are the result of designers listening to customers. This has led to the development of a user-friendly VSI which gives the lowest possible total cost per tonne by improving energy efficiency, reducing wear rates, lengthening intervals between servicing, reducing the time required to perform service tasks, as well as improving crushing performance and control.

Adaptable and versatile

The Barmac B-Series VSI is an excellent third or fourth stage reduction unit and has demonstrated a unique ability to operate in many demanding and diverse crushing operations in construction, industrial minerals, metallic minerals and waste and recycling applications. This is possible because of the unique free impact crushing and grinding action and the ability to fine-tune this process by simply changing rotor speed or cascade ratio.

Coupled with lower wear costs, the result has seen the Barmac B-Series VSI find applications not only in traditional quarry and mining plants, but also in a range of industrial mineral and specialist crushing operations.



The Barmac B-Series VSI's roof lifter allows easy access for servicing the machine, ensuring minimal downtime.



The Barmac B-Series VSI is designed with ease of installation in mind.

Your competitive advantage

The complete range of Barmac B-Series VSI crushers incorporate rock-on-rock crushing technology that has revolutionised the aggregates and minerals industries worldwide.

The rock-on-rock Barmac B-Series VSI offers the modern operator product grading control by optimising numerous variables:

- Variation of rotor speed.
- Choice of crushing chamber cavity rings.
- Adjustment of cascade feed ratio.
- Selection of different diameter rotors.

Designed for low service requirements and ease of operation, the Barmac B-Series VSI will readily fit into any existing or proposed crushing plant.

Barmac B-Series VSI features

- Accepts sticky feeds.
- Accepts all in feeds.
- Competitive capital cost, especially when compared with conventional crushing equipment.
- Low service and maintenance requirements along with minimum operating and wear costs.

- Rock-on-rock technology minimises wear part requirements.
- Quick and easy installation. Crushers require minimum support structure and are also ideal as mobile units.
- Ability to control product grading, maximising or minimising fines production.
- Produces a product of superior cubical shape.
- Superior mineral liberation and increased recovery rates.
- Preferential crushing action.
- Integrated monitoring, safety and control systems.
- More tolerant than conventional crushers to difficult feed conditions.
- Simple, reliable grease lubrication.
- Range of models available to suit any capacity in tertiary or quaternary applications.

The User-Friendly VSI crusher

The Barmac B-Series VSI is designed with ease of installation in mind. Assembly, installation and commissioning can be achieved by two people in 2-3 days. Foundation requirements are minimal due

to the light weight of the machine and the minimal dynamic forces when in operation. Existing support work can be used or a support structure can be supplied.

The Barmac B-Series VSI provides higher capacity for a given motor size, easier servicing and reduced operating costs. Benefits have been achieved by an improved machine design, including a new hopper configuration, radical crushing chamber variations and the development of new rotor technology. Service time is drastically reduced with complete access to all rotor parts, simplifying wear part replacement procedures.

The roof lifter has been developed to provide quick and easy access to the internal workings of the Barmac B-Series VSI. This allows for rapid rotor and wear part changes and minimises down time while maximising availability. The simple and reliable design of the roof lifter means only one person is required for operation and can eliminate the requirement for an external crane.

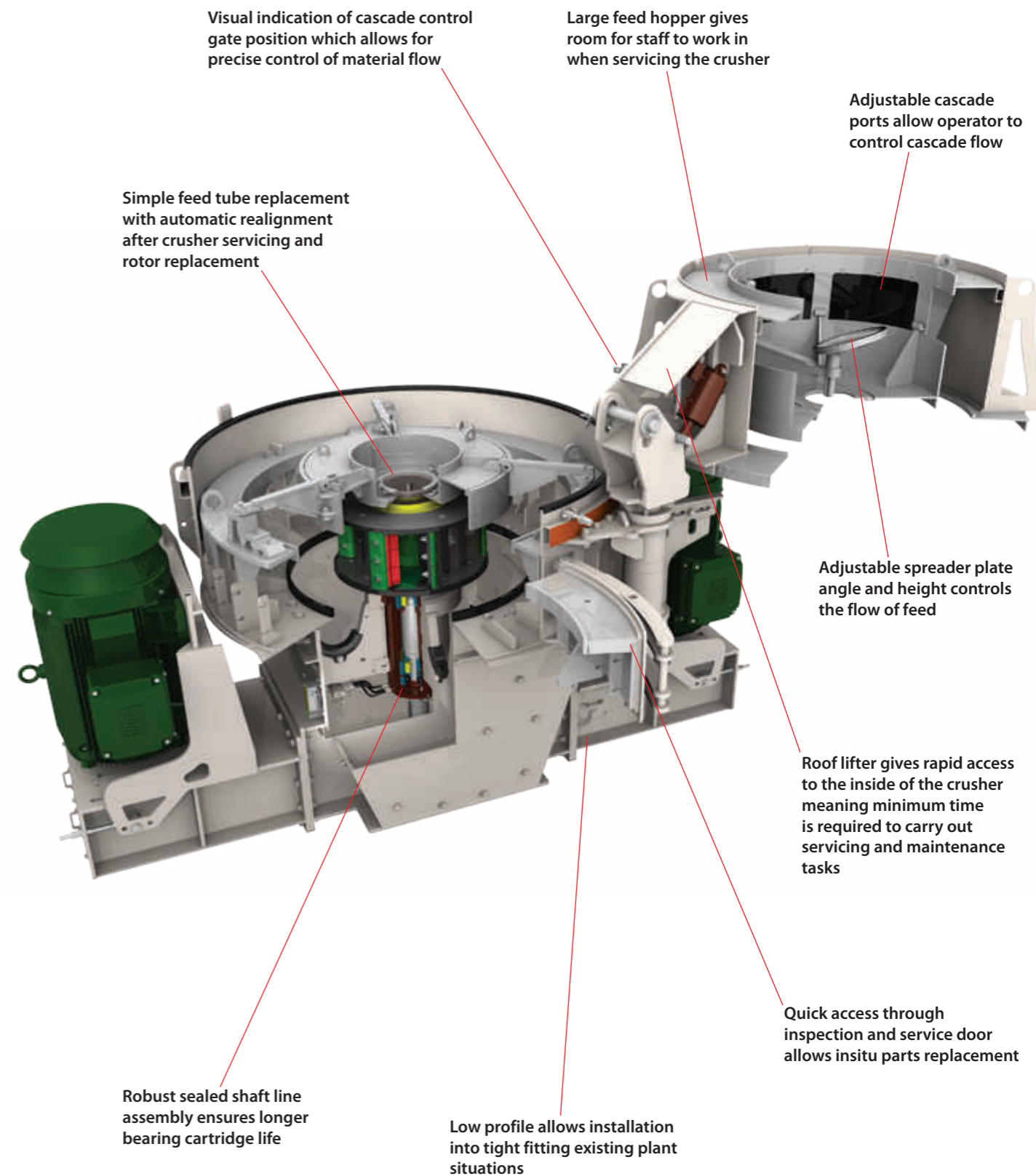

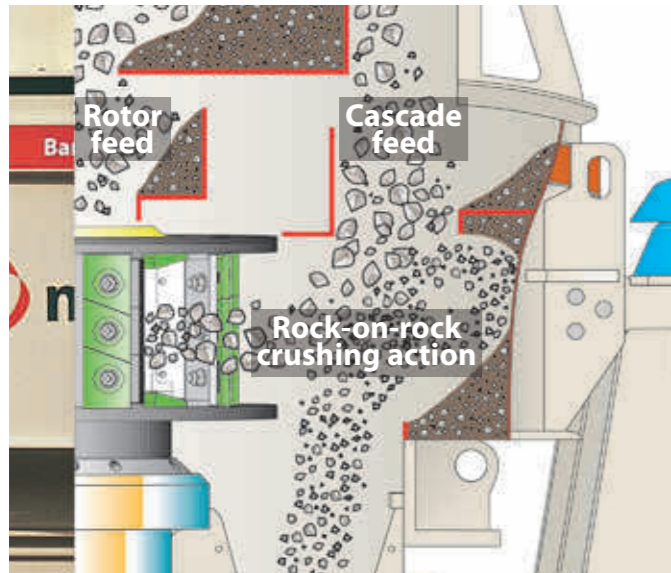

Crushing in the Barmac B-Series VSI.



Material may be introduced into the crushing chamber via cascade, thus bypassing the rotor.

Supercharge your crushing process

The Barmac B-Series VSI uses the cascade feed system to introduce a second stream of material, in a controlled quantity, into the crushing chamber turbulence.

This causes a supercharging of the particle population within the chamber, thereby improving the energy transfer between the particles. The cascade feature enables the operator to make optimal use of the power available and to manipulate the product grading and shape to best suit their requirements.

The primary path for feed material is through the rotor through which material is accelerated to speeds of up to 80m/s (262ft/s) before being discharged into the

crushing chamber. Additionally, material may be introduced into the crushing chamber via cascade, thus bypassing the rotor.

Improved efficiency and throughput

Cascading material combines with material from the rotor to form a denser particle population, which optimises reduction by increasing the chance of a good rock-on-rock collision. This most efficient use of the rock-on-rock crushing action leads to improved crusher efficiency and increased throughput, giving the operator more value for money by providing more inter-particle action where it is needed most - in the crushing chamber.

The effect of increasing material through

cascade is similar to slowing the rotor. This has the effect of changing the product curve and product shape if increased amounts of cascade are used. Up to 10% cascade can be utilised with no measurable change in product gradation or quality. That means 10% extra product for no extra power use or wear part consumption. It is important to remember that increasing the cascade percentage further will have a detrimental effect on product shape.

Cascade provides greater flexibility and control of the product produced by the Barmac B-Series VSI – flexibility that can accommodate changes in feed specification and control that provides total management of product quality and fines content.

The graphs below are indicative examples of the effect cascade has on productivity and power consumption.

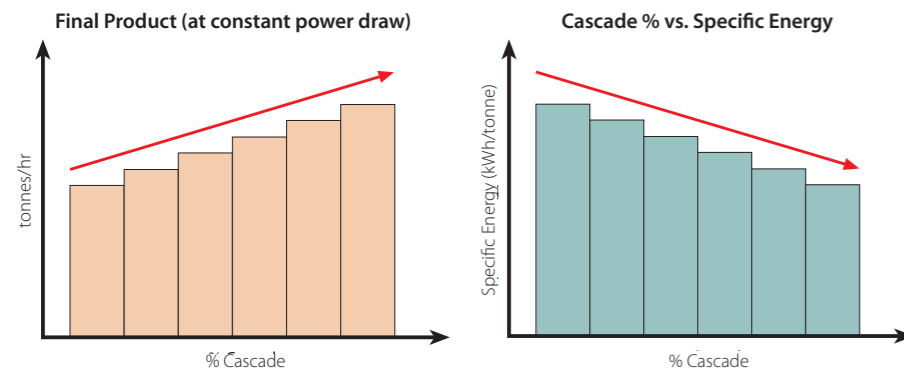

The cascade feed system provides:

- Higher crusher throughputs for the same power consumption.
- Maximum use of available power without fear of motor overload.
- Gradation control to optimise product fractions.
- 'Free' crushing at no extra expense to the operator.
- Shape control.

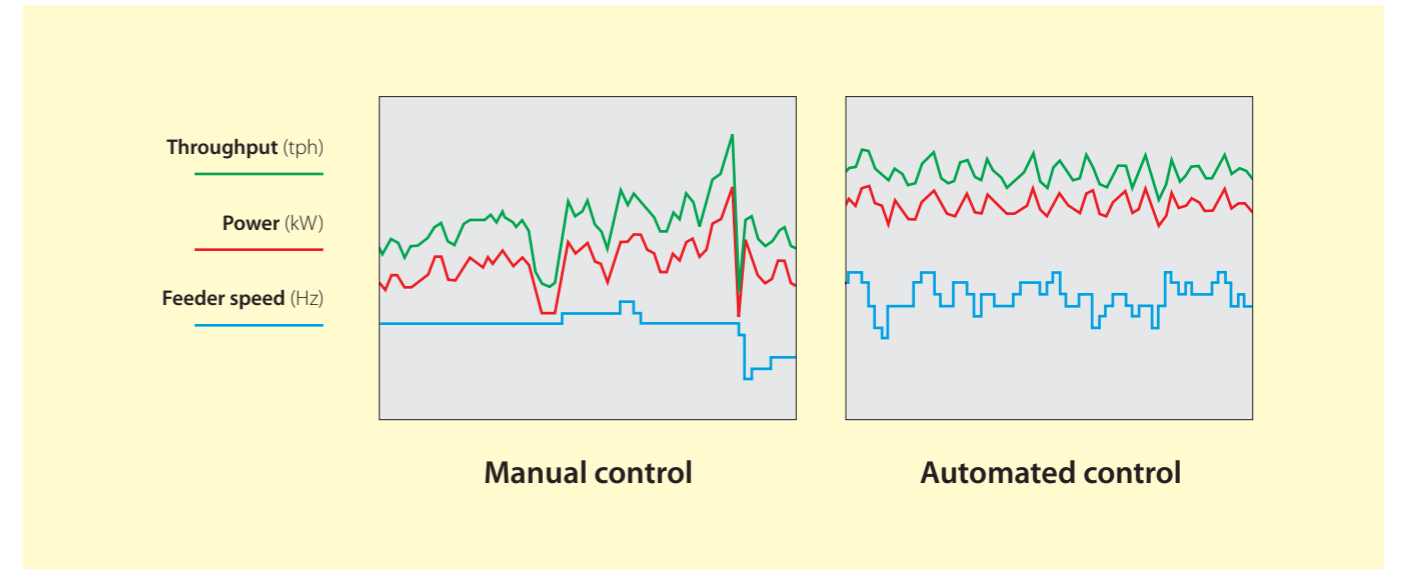

This graphic shows the way in which the Barmac B-Series VSI automation system can maintain throughput and power at more consistent and higher levels through adjustment of cascade gate position and feeder speed.

Maximise the potential of your Barmac B-Series VSI

Experience has proven that the key to profits in the aggregate production and minerals processing industries lie in the ability to produce consistent products of high quality.

Automation is playing an increasingly important role in the development of the crushing process. Recent advances in aggregate and mineral processing technology call for a higher degree of control. For process operators, the result is greater efficiency and plant flexibility and, ultimately, improved product quality and cost-efficiency.

Automating your Barmac B-Series VSI

Automating your Barmac B-Series VSI will ultimately lead to increased profits. Metso offers the most advanced automation technology with control and monitoring devices that make the integration of a Barmac B-Series VSI into a modern plant a formality.

Today's operators are looking for suppliers who focus on solutions, not just products. With this in mind, Metso has developed the

IC automation system, including dedicated Barmac VSI software, to provide increased flexibility and versatility, while supporting easy operation and maintenance. This allows seamless integration of your Barmac B-Series VSI with the rest of your Metso plant.

Automating the Barmac B-Series VSI crushing process allows the operator to keep crushing at maximum operational limits, but within safety margins, and contributes significantly to the efficiency and availability of the crusher. It allows the operator to take full advantage of the features offered by the Barmac B-Series VSI by gaining precise control of the machine's ability to cascade and by gaining complete control over product grading and cost per tonne.

Precise control of the crushing process is the key to profitability

For accurate control of product specification and grading, the cascade ratio can be hydraulically adjusted while the crusher is operating. Adjustment can be hand operated or be fully integrated into automated plant systems.

The Barmac B-Series VSI automation system makes it possible to adjust the cascade ratio and feed rate to the Barmac B-Series VSI to maximise productivity and efficiency for a given installation and crusher duty. This adjustment can be made by opening and closing the cascade gate and adjusting the feeder setting to achieve the desired feed rate.

Automation makes it possible to perform analysis and corrective actions based on process variations. It allows the operator to program in the right crusher settings quickly and easily for a desired product, and maintain those settings to maximise production.

As an example, a given application uses 15% cascade with a rotor speed of 55m/s and a crusher throughput of 200 tph that gives the right product quality and the right balance of the different product fractions. The automation system will enable the Barmac B-Series VSI to maintain these optimal settings and remove the need for regular manual adjustments, thus maximising productivity, minimising costs and ensuring a consistent product.



Barmac B-Series VSI crushers process a diverse range of materials in applications across the globe.



The Barmac B-Series VSI is a producer of superior shaped product.



An established track record

Barmac B-Series VSI crushers are operating in aggregate and mineral processing installations around the world with an established track record of cost savings, durability and unmatched performance.

Metso has the technology and experience in applying and servicing the Barmac B-Series VSI across the globe in an extensive variety of applications, processing a diverse range of materials.

The unmatched producer of superior concrete and asphalt aggregate

Less cement can be used and stronger concrete created by using Barmac B-Series VSI product. The Barmac B-Series VSI combines high velocity impact crushing with high pressure attrition grinding to produce

high volumes of cubically shaped product. Continuous control of the product shape and gradation provides a product which meets the size distribution required.

A proven producer of quality manufactured sand

Superior particle shape and consistent gradation are a direct result of the rock-on-rock principle of the VSI crusher. Impact, grinding and abrading within the crusher simulates the action of nature, eroding the particles to a cubical shape.

The perfect pre-mill crusher to improve mill circuit performance

The Barmac B-Series VSI reduces power requirements and increases mill capacity

by reducing the top size and increasing the fineness of the mill feed. Mill liner life is increased by providing a finer mill feed, allowing the use of smaller mill balls to achieve the required size reduction.

The producer of fine products for the industrial minerals industry

The Barmac B-Series VSI's crushing action gives a product with a large surface area, which gives increased recovery of the desired mineral. The free impact reduction will preferentially crush a more friable mineral when separating a desirable product from a waste material.

The only viable crusher for extremely abrasive fine material

The rock-on-rock crushing principle of the Barmac B-Series VSI minimises metallic wear resulting in low maintenance and wear costs. The low wear of internal components ensures extremely low contamination of fine products by wearing metal parts.



The Barmac B-Series VSI produces high quality crushed sand.



Highly abrasive feed, such as material for refractory bricks, are successfully processed in the Barmac B-Series VSI.



Glass can be processed and recycled using a Barmac B-Series VSI.



The NW7150 is part of Metso's wheel-mounted portable offering.



The LT7150 is available as part of Metso's Lokotrack range of products.

Application areas

Aggregates and sand

The quarry industry has been the traditional home of the Barmac VSI. Barmac B-Series VSIs have consistently demonstrated their ability to produce high quality cubical shaped aggregates that meet all major construction specifications. Barmac B-Series VSIs are particularly successful in producing road-base, top dressing chip, concrete and asphalt aggregates, and manufactured sand.

In these applications, Barmac B-Series VSIs can be operated either in open or closed circuit, depending on the types of aggregates and the specifications required.

Industrial minerals

With features such as controlled product grading, preferential crushing, low production costs and the ability to produce finely graded products, the addition of a Barmac B-Series VSI can optimise the performance of most industrial mineral processing installations.

In this sector, Barmac B-Series VSIs are very popular as cost-effective fine crushing equipment for the abrasive industry. Diamond mines are another sector that is becoming increasingly associated with the Barmac B-Series VSI, which is looked upon as effective equipment for liberating diamonds from gangue minerals. Fine crushing cement clinker is fast becoming the Barmac B-Series VSI's forte with its proven ability as a cost-effective pre-grinder.

Mining

In mining (metallic minerals), the Barmac B-Series VSI, with its high capacity and ability to produce finely graded products such as mill feed, sinter feed or material for heap leach operations, is an ideal machine to replace high cost, inefficient crushing and milling equipment.

The addition of a Barmac B-Series VSI to an existing circuit can save considerable capital

funds when increased production is required from an existing milling circuit.

Waste recycling

Waste recycling is not only environmentally responsible, it is also economically viable. As the areas of recycling continue to increase and the global community moves closer towards higher environmental consciousness, the Barmac B-Series VSI is establishing market areas where it can outperform other methods of recycling recovery efficiency.

Recycled materials not only take the form of mineral aggregates for the construction industry, but also glass, slags and other waste products that can be processed and profitably sold. The Barmac B-Series VSI provides the perfect means of treating these materials. The versatility of the Barmac B-Series VSI allows it to be used to great effect in many applications.

Contracting

Metso pioneered the development of fully mobile crushing and screening plants. Our track- and wheel-mounted portable plant concepts are fully adaptable to all mobile crushing needs, opening up a whole new range of business opportunities for contractors, quarry operators, recycling and mining applications.

Mobile processing is continuing to increase its market share. Besides full portability, mobile processing offers several other advantages like flexible process adjustability, less trucking, less manpower needs and compliance with strict environmental standards.

The Barmac B-Series VSI is now included as part of Metso's portable plant range. There is a Barmac VSI option available if your portable application calls for superior cubical, well-shaped product.

Wheels or tracks - it's your choice

Compared to stationary applications, the set-up time for portable plants can be counted in hours rather than days. This means more flexible operation and cost savings thanks

to maximised crushing time. The improved mobility of Metso's portable plants increases opportunities to crush material on-site. This, in turn, substantially reduces the cost of transporting material for off-site crushing.

Our contracting solutions offer you true mobility, high capacity, quality end products and reliable operation. Nordberg NW and Lokotrack LT mobile crushing plants are engineered and built to work together smoothly even in the most demanding applications.

The Nordberg NW Series wheel-mounted portable plant features a high chassis, short wheel base and tight turning radius meaning they can be transported on highways and

moved to crushing sites that otherwise might be difficult to access. The Lokotrack LT Series represents a guaranteed, state-of-the-art commitment to crushing and screening know-how and quality.

Enhance your profitability

Metso has delivered well over 7000 mobile crushing and screening plants: for contract crushing and screening, quarry operations, minerals processing and recycling sites.

Guarantee your next contract by choosing the leading, field proven mobile processing equipment. Invest in Metso, the world leader in mobile processing, and start improving the profitability of your operation!



Portable plants can be set up in hours, rather than days, allowing operators to maximise their crushing time.



Genuine Barmac VSI parts help guarantee the extended life of your machine.



Metso and our distributors provide service that will help our customers best use their Barmac B-Series VSI.

Service and support - our specialty

Metso has parts available to a high standard of fit, quality and presentation and we endeavour to have them available close to our customers.

Where we have local representation, we have set up rotor refurbishment facilities to provide consistent high quality rotor rebuilds. For the Barmac B-Series VSI, rotor maintenance is a large proportion of the total maintenance cost of the machine. It is critical to have well maintained rotors to ensure the longevity of the shaft line assembly, as well as for the useable life of the rotor itself.

Where the rotor refurbishment work has been done by Metso, it is noticeable that bearing cartridge life is extended dramatically. Refurbishing Barmac B-Series VSI rotors allows us to spend more time with customers and their machines, which allows us the opportunity to offer advice to help get the most from the crusher.

Site visits may indicate a need for a general machine audit to highlight the condition of other parts of the Barmac VSI through its life, as well as to ensure the machine is being run to its potential.

Life cycle service

Metso, using its long-term experience of crushing equipment and crushing processes, has developed an expert service offering aimed at improving the reliability and productivity of customer operations. Our customer service organisation is available worldwide to add value through customer-specific solutions.

Metso's life cycle services cover all areas of the crushing, size reduction and classifying process, and are aimed at improving the customer's end-product value.

Customer service is not, and can not, be limited to machine operation alone. Machines are bought to perform a task. How that task is performed and what results from that operation are of keen interest to both parties, customers and manufacturers alike. Metso provides service that extends to support not only in how best to use your machines, but also in how best to use your product.

Product from a correctly run Barmac B-Series VSI is nothing short of supreme. This means you will save on the cost of operating the crusher and you should also be able to gain a premium on your end product.

Genuine quality spare and wear parts

Our genuine, high quality parts will give you the assurance of correct metallurgy, precise engineering and ideal suitability for trouble-free operation, so you can produce the quality products your equipment is designed for, providing value for you and your customers.

Benefit from our extensive applications experience in supplying the right wear alloys for long life and reduced wear costs in your specific crushing operation. When you choose a Barmac B-Series VSI you have the security of knowing that every piece of equipment is backed by unmatched parts availability and service, no matter how remote your location.

Metso's complete service support package includes upgrades and genuine OEM parts for older model Barmac B-Series VSIs. The skills and knowledge acquired from over 35 years of developing, manufacturing, applying and servicing the Barmac B-Series VSI allow the best solutions to help you maximise the potential of your operation.



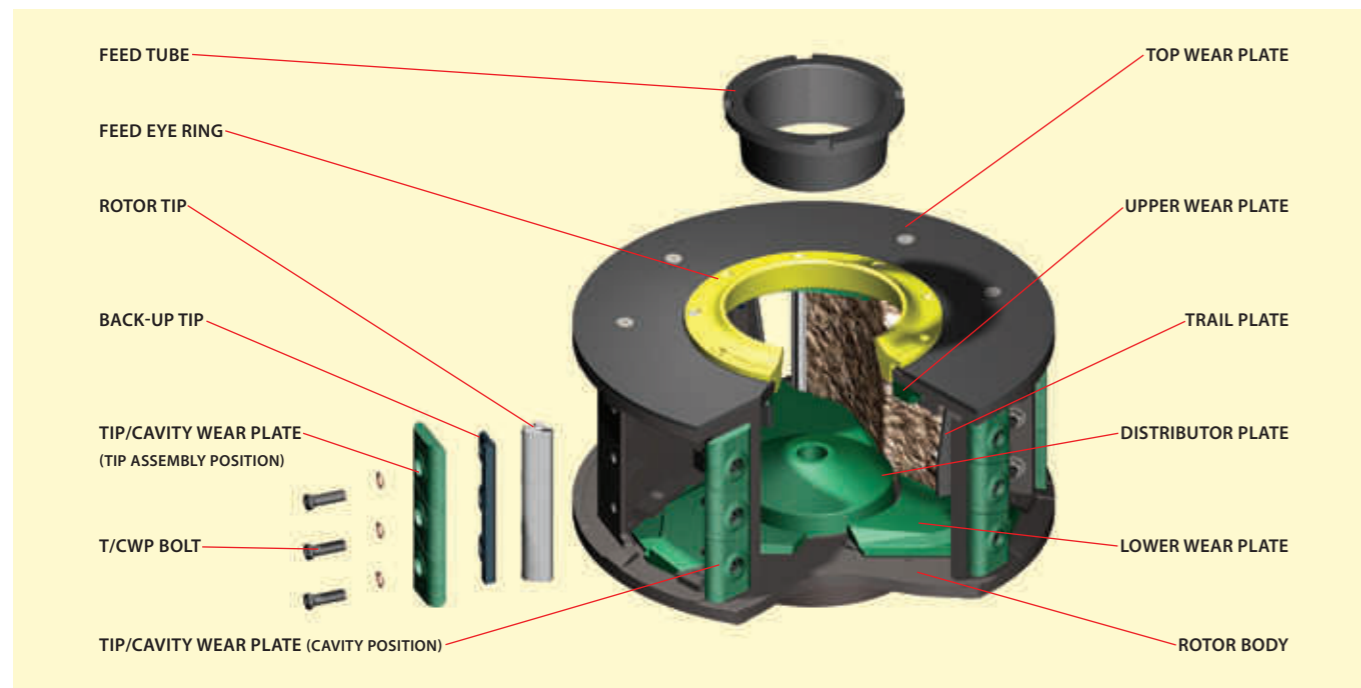

The heart of the Barmac B-Series VSI

The success of the Barmac B-Series VSI is centred around its rotor.

In simple terms, crusher operators wish to reduce their running costs while still making the product they need. This means reducing downtime, wear part usage and power consumption while still maintaining product gradation. The Barmac VSI DTR deep rotor is the ideal tool for achieving this because it has been developed specifically to increase throughputs and reduce wear costs.

The development of deep rotor technology, combined with long life wear parts and segmented tip assemblies, dramatically reduces down time associated with wear part replacement.

Real advantages for the operator

Extensive testing worldwide has shown that deep rotor technology has increased product throughput, in some cases by up to 30%. It has also led to a reduction in downtime,

service labour costs and wear costs. These lead to very real monetary advantages.

In addition, the capability to handle coarse feed fractions has been improved. Reduced energy consumption can be experienced with potential savings of up to 20%, making the crusher more energy efficient. So why waste your energy wearing out parts when you could be using it to crush rock?

Why go deep?

The Barmac DTR rotor is designed with serviceability and optimal rotor and wear part life in mind. Power consumption and rotor wear are both reduced by creating more room for material to enter and pass through the rotor.

Since running an AC motor at less than full load current is inefficient we can make the most of this power saving in three ways:

- Increase rotor throughput – leads to gains in product quantity.

- Increase rotor speed – leads to increased product quality.
- Install a smaller motor – provides gains in power saving.

This will give the operator:

- Lower wear costs per tonne. In some cases average wear part lives have increased by 50%. This means less maintenance time and higher crusher availability.
- Lower power consumption/draw per tonne.
- Higher throughput for a given power consumption.
- Lower power consumption for a given throughput.
- Higher capacity. A denser particle population in the chamber will give more effective reduction and improved shape.
- Improved flowability due to the higher clearance height within the rotor, especially with coarse feeds.



Barmac B6150SE VSI crusher

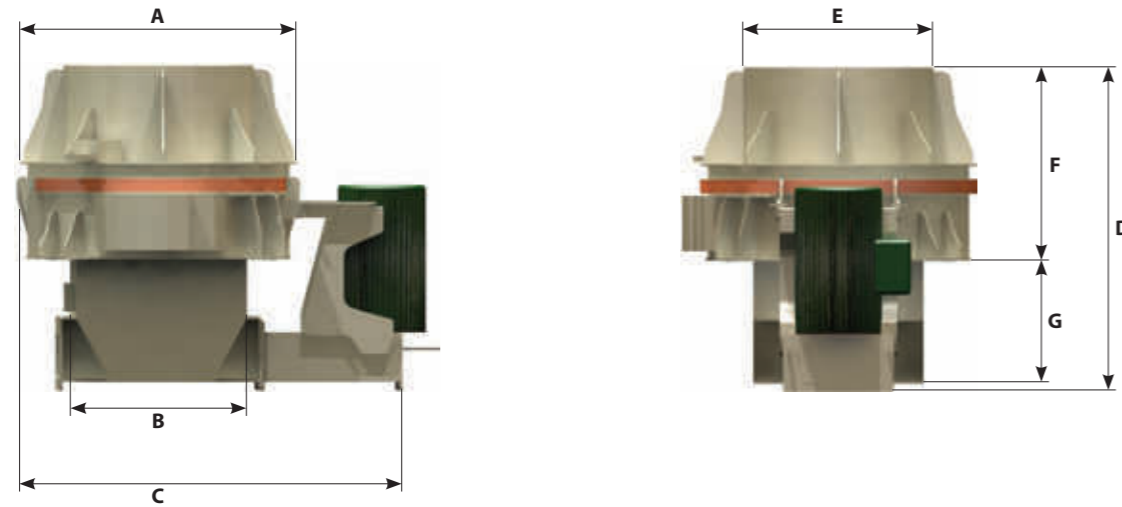

DIMENSIONS	[mm]	[inch]
A	1870	73½
B	1150	45¼
C	2575	101½
D	2189	86¼
E	1260	49½
F	1304	51¼
G	830	32¾



Typical dry weight, including motors (pictured above) = 6371kg [13999lb]

Barmac B7150SE VSI crusher

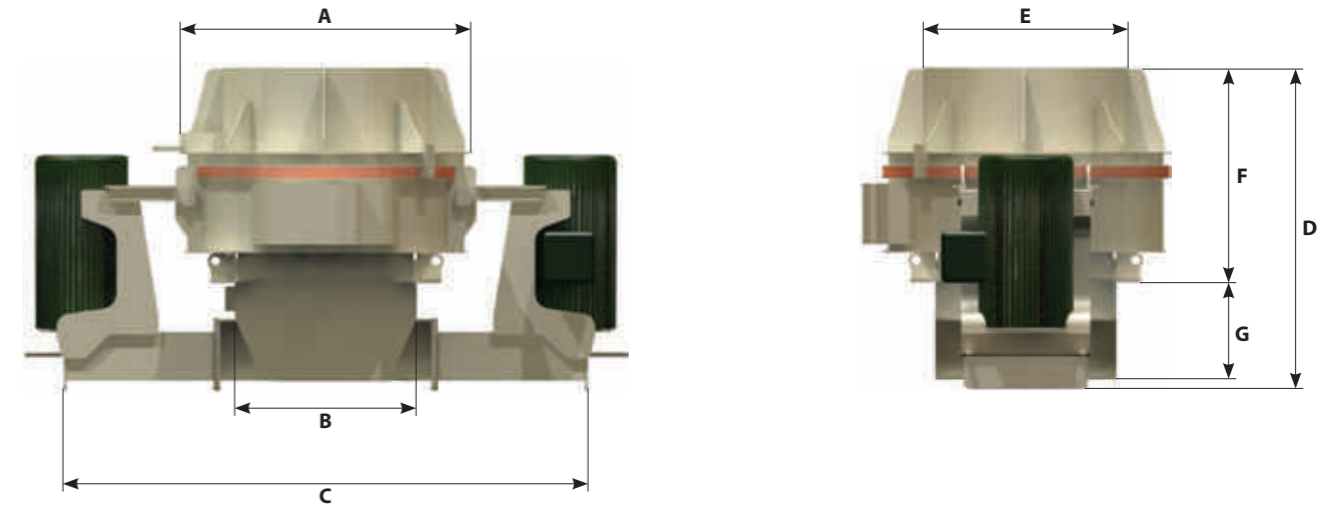

DIMENSIONS	[mm]	[inch]
A	2220	87½
B	1394	55
C	4020	158¼
D	2469	97¼
E	1575	62
F	1644	64¾
G	755	29¾



Typical dry weight, including motors (pictured above) = 12395kg [27269lb]

Application Specifications

Feed Size 37mm [1½"] max. longest dimension • 37mm [1½"] max. square mesh

Rotor RPM Range 1500 – 2500

Crusher Capacity - metric tonnes per hour [short tonnes per hour]

Installed Power	75kW [100hp]	92kW [125hp]	110kW [150hp]	132kW [175hp]	150kW [200hp]
Drive Configuration	Single	Single	Single	Single	Single
General Crushing	60–103 [66–113]	60–134 [66–147]	66–168 [73–185]	77–202 [85–222]	100–217 [110–238]
Shaping	60–103 [66–113]	60–134 [66–147]	66–168 [73–185]	77–202 [85–222]	100–217 [110–238]
Manufactured Sand/Fine Crushing	60–92 [66–101]	60–121 [66–133]	66–151 [73–166]	77–181 [85–199]	100–193 [110–212]

The capacities shown in this table will alter with changes to the selected operating parameters of the Barmac B6150SE VSI, including rotor speed and cascade percentage, along with variations in the physical characteristics of the feed material. Please consult a Metso applications department for specific capacity details.

The figures in the table above were calculated as follows: Lower limit = rotor tip speed of 70m/s with 0% cascade. Upper limit = rotor tip speed of 45m/s with 30% cascade.

The recommended minimum capacity for the Barmac B6150SE VSI is 60 mtp. If below 60 mtp, poor chamber build-up may be experienced in some applications, which will cause accelerated wear and reduced crushing efficiency.

Application Specifications

Feed Size 57mm [2¼"] max. longest dimension • 45mm [1¾"] max. square mesh

Rotor RPM Range 1100 – 2100

Crusher Capacity - metric tonnes per hour [short tonnes per hour]

Installed Power	185kW [250hp]	220kW [300hp]	260kW [350hp]	300kW [400hp]
Drive Configuration	Single	Single	Dual	Dual
General Crushing	125–298 [137–327]	150–378 [165–415]	175–460 [192–505]	200–545 [220–599]
Shaping	125–298 [137–327]	150–378 [165–415]	175–460 [192–505]	200–545 [220–599]
Manufactured Sand/Fine Crushing	125–265 [137–291]	150–332 [165–365]	175–405 [192–445]	200–465 [220–511]

The capacities shown in this table will alter with changes to the selected operating parameters of the Barmac B7150SE VSI, including rotor speed and cascade percentage, along with variations in the physical characteristics of the feed material. Please consult a Metso applications department for specific capacity details.

The figures in the table above were calculated as follows: Lower limit = rotor tip speed of 70m/s with 0% cascade. Upper limit = rotor tip speed of 45m/s with 30% cascade.

Barmac B9100SE VSI crusher

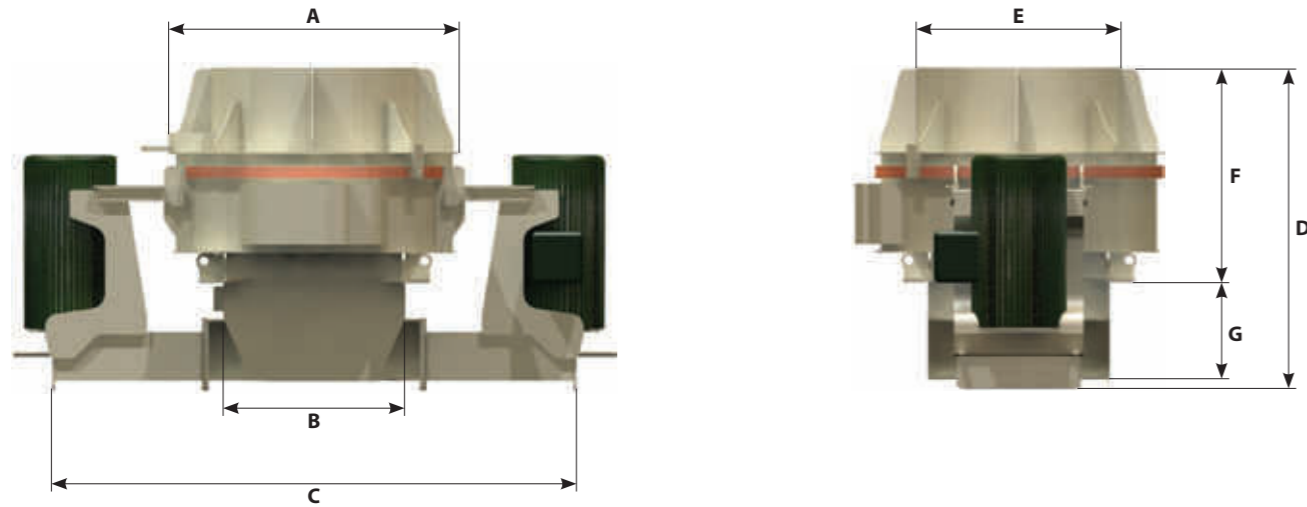

DIMENSIONS	[mm]	[inch]
A	2434	95¾
B	1394	55
C	4020	158¾
D	2813	110¾
E	1775	69¾
F	1744	68¾
G	994	39



Typical dry weight, including motors (pictured above) = 14357kg [31585lb]

Application Specifications

Feed Size 64mm [2½"] max. longest dimension • 50mm [2"] max. square mesh

Rotor RPM Range 1000 – 1800

Crusher Capacity - metric tonnes per hour [short tonnes per hour]

Installed Power	370kW [500hp]	440kW [600hp]	520kW [700hp]	600kW [800hp]
Drive Configuration	Dual	Dual	Dual	Dual
General Crushing	263–629 [289–691]	315–725 [346–797]	368–765 [404–841]	420–775 [462–852]
Shaping	263–629 [289–691]	315–725 [346–797]	368–765 [404–841]	420–775 [462–852]
Manufactured Sand/Fine Crushing	263–554 [289–609]	315–725 [346–797]	368–765 [404–841]	420–775 [462–852]

The capacities shown in this table will alter with changes to the selected operating parameters of the Barmac B9100SE VSI, including rotor speed and cascade percentage, along with variations in the physical characteristics of the feed material. Please consult a Metso applications department for specific capacity details.

The figures in the table above were calculated as follows: Lower limit = rotor tip speed of 70m/s with 0% cascade. Upper limit = rotor tip speed of 45m/s with 30% cascade.





Expect results

Expect results is our promise to our customers and the essence of our strategy. It is the attitude we share globally. Our business is to deliver results to our customers, to help them reach their goals

